

Amphenol MS3450 (Matrix®) Series MIL-DTL-5015



MIL-DTL-5015 Rear Release Crimp

HIGH-PERFORMANCE ALTERNATIVE TO OLDER MIL-DTL-5015 SOLDER TYPES

The MIL-DTL-5015 Rear-Release Threaded MS3450 Matrix® series uses rear-release crimp contacts with retention clip. These Amphenol connectors fill the gap between older MIL-DTL-5015s and the environmental and higher-performance needs of new technologies. They are sealed to withstand moisture, condensation, vibration and flash-over. Over 165 contact layouts are available, in variations that allow for just power, just signal, or a mix of both contact types.

- Formerly MIL-C-5015

APPLICATIONS

Military, industrial and commercial environments requiring extreme reliability, high-power handling and cost efficiency.

- Power generators
- Engines
- Sensors
- Motion control
- Off-road vehicles
- Earth-moving equipment
- Ships
- Mobile equipment
- Industrial machinery
- Telecommunications

FEATURES

BROAD OPERATING TEMPERATURES

The electroless nickel plating and stainless steel shell connectors will operate in temperature ranges from -75°F to +392°F (-55°C to 200°C). The cadmium olive drab plating connectors will operate in temperatures ranging from -75°F to +347°F (-55°C to 175°C).

ENVIRONMENTAL

These connectors will perform in the full range of operating conditions defined in MIL-DTL-5015 and are recommended for conditions where vibration, moisture, pressure, and/or temperatures are extreme.

RUGGED SHELL

The rugged aluminum alloy or steel shell are highly resistant to damage and corrosion with firewall capabilities. Shells are available in four different styles, like a self-locking coupling nut in seventeen different sizes.

WIDE RANGE OF WIRE GAUGES AND CURRENT-CARRYING CAPACITY

Up to 150 amps for standard military contacts and wire gauges from size 20 to size 0 AWG.

**TECHNICAL
SPECIFICATIONS**
MATERIALS & FINISHES

Shell	Aluminum alloy, steel and stainless steel
Plating	Olive drab chromate over cadmium per QQ-P-416, electroless nickel per ASTM B73 or black anodize for aluminum; olive drab chromate over cadmium or passivated steel
Contacts	Copper alloy
Plating	Gold-plated
Insulator	Neoprene
Seals	Silicone

ELECTRICAL DATA

Operating Voltage/Test Voltage

MS SERVICE RATING	NOMINAL DISTANCE		OPERATING VOLTAGE*		STANDARD SEA LEVEL CONDITIONS		PRESSURE ALTITUDE† 50,000 FEET		PRESSURE ALTITUDE† 70,000 FEET	
	AIRSPACE	CREEPAGE	DC V	AC VRMS	MINIMUM FLASHOVER VOLTAGE AC (RMS)	TEST VOLTAGE AC (RMS)	MINIMUM FLASHOVER VOLTAGE AC (RMS)	TEST VOLTAGE AC (RMS)	MINIMUM FLASHOVER VOLTAGE AC (RMS)	TEST VOLTAGE AC (RMS)
I	1/32	1/16	250	200	1,400	1,000	550	400	325	260
A	1/16	1/8	700	500	2,800	2,000	800	600	450	360
D	1/8	3/16	1,250	900	3,600	2,800	900	675	500	400
E	3/16	1/4	1,750	1,250	4,500	3,500	1,000	750	550	440
B	1/4	5/16	2,450	1,750	5,700	4,500	1,100	825	600	480
C	5/16	1	4,200	3,000	8,500	7,000	1,300	975	700	560

* Each insulator has a specific service rating. These numbers should be used by the designer only as a guide. The Service Ratings for each layout are listed on [pages 72-93](#).

† Not corrected for change in density resulting from variations in temperature.

MS connectors show no evidence of breakdown when the given test voltages are applied between the two closest contacts and between the shell and the contacts closest to the shell for a period of one minute, per MIL-STD-1344 Method 3001.

Current Rating & Contact Resistance	CONTACT SIZE	TEST CURRENT (AMPS)	POTENTIAL DROP (MILLIVOLTS)	CONTACT RESISTANCE (MILLIOHM) MAX.
	16	13	50	6
	12	23	50	3
	8	46	29	1 (0.44*)
	4	80	14	0.5 (0.23*)
	0	150	12	0.2 (0.18*)

*Using non-military crimp Radsok contact

Maximum total current to be carried per connector in wire bundles as specified in MIL-W-5088. Contact resistance when tested to MIL-C-39029 will not exceed voltage drops listed in above table.

Wire Range Sizes	20 AWG – 0 AWG
Insulation Resistance	50,000 megohms minimum at 77°F (25°C) 1,000 megohm minimum at 392°F (200°C) Class L and 347°F (175°C) Class W

MECHANICAL

Operating	Classes L, LS and KS -75°F to 392°F (-55°C to +200°C) Temperature classes W and KT -75°F to 347°F (-55°C to 175°C)																		
Wire Sealing Range	<table border="1"> <thead> <tr> <th>CONTACT SIZE</th> <th>WIRE SEALING RANGE MIN.</th> <th>WIRE SEALING RANGE MAX.</th> </tr> </thead> <tbody> <tr> <td>16/16S</td> <td>0.053 (1.35)</td> <td>0.103 (2.62)</td> </tr> <tr> <td>12</td> <td>0.085 (2.16)</td> <td>0.158 (4.01)</td> </tr> <tr> <td>8</td> <td>0.132 (3.35)</td> <td>0.255 (6.48)</td> </tr> <tr> <td>4</td> <td>0.237 (6.02)</td> <td>0.370 (9.40)</td> </tr> <tr> <td>0</td> <td>0.360 (9.14)</td> <td>0.550 (13.97)</td> </tr> </tbody> </table>	CONTACT SIZE	WIRE SEALING RANGE MIN.	WIRE SEALING RANGE MAX.	16/16S	0.053 (1.35)	0.103 (2.62)	12	0.085 (2.16)	0.158 (4.01)	8	0.132 (3.35)	0.255 (6.48)	4	0.237 (6.02)	0.370 (9.40)	0	0.360 (9.14)	0.550 (13.97)
CONTACT SIZE	WIRE SEALING RANGE MIN.	WIRE SEALING RANGE MAX.																	
16/16S	0.053 (1.35)	0.103 (2.62)																	
12	0.085 (2.16)	0.158 (4.01)																	
8	0.132 (3.35)	0.255 (6.48)																	
4	0.237 (6.02)	0.370 (9.40)																	
0	0.360 (9.14)	0.550 (13.97)																	

TECHNICAL SPECIFICATIONS

Insulation Strip Length	CONTACT SIZE	STRIP LENGTH
	16/16S	.245 (6.2)
	12	.245 (6.2)
	8	.465 (11.8)
	4	.465 (11.8)
	0	.540 (13.7)
Mating Life	100 cycles minimum	
Salt Spray	Class L & W 48 hours unmated; 48 hours mated per MIL-STD-1344 method 1001 condition letter A, paragraph 4.6.13.2 of MIL-DTL-5015, Class LS, KT, KS 952 hours mated, 48 hours unmated per MIL-STD-1344, method 1001 condition letter D, paragraph 4.6.13.3 of MIL-DTL5015	
Heat	Class L, LS & KS, +392°F (+200°C); Class W, KT, +347°F (+175°C)	
Chemical Resistance	20-hour full-immersion unmated in hydraulic fluid and lubricating oil per MIL-DTL-5015 minimum	
Vibration	10 to 2,000Hz (10g's) 10 microseconds maximum discontinuity to MIL-STD-1344 Method 2005, condition II per MIL-DTL-5015	
Shock	50g 11millisecond duration, three major axes. 10 microseconds maximum discontinuity to MIL-DTL-5015 per MIL-STD-1344 method 2004, condition A, 3.13.	
Contact Type	Rear-release crimp	
Number of Circuits	1 to 85	
Contact Insertion & Extraction	Insertion from rear of connector with simple plastic or high-quality metal hand tool. Extraction from rear with plastic or high-quality metal hand tools.	
Contact Retention	Per MIL-DTL-5015, 3.10 & 4.6.6.	
	CONTACT SIZE	AXIAL LOAD LBS. MIN.
	16	25
	12	30
	8	50
	4	60
	0	75
Polarization	Integral key and keyway plus optional rotational polarization. ➔ See pages 83-93 for valid rotations.	
Approvals	MIL-DTL-5015 (MIL-C-5015)	

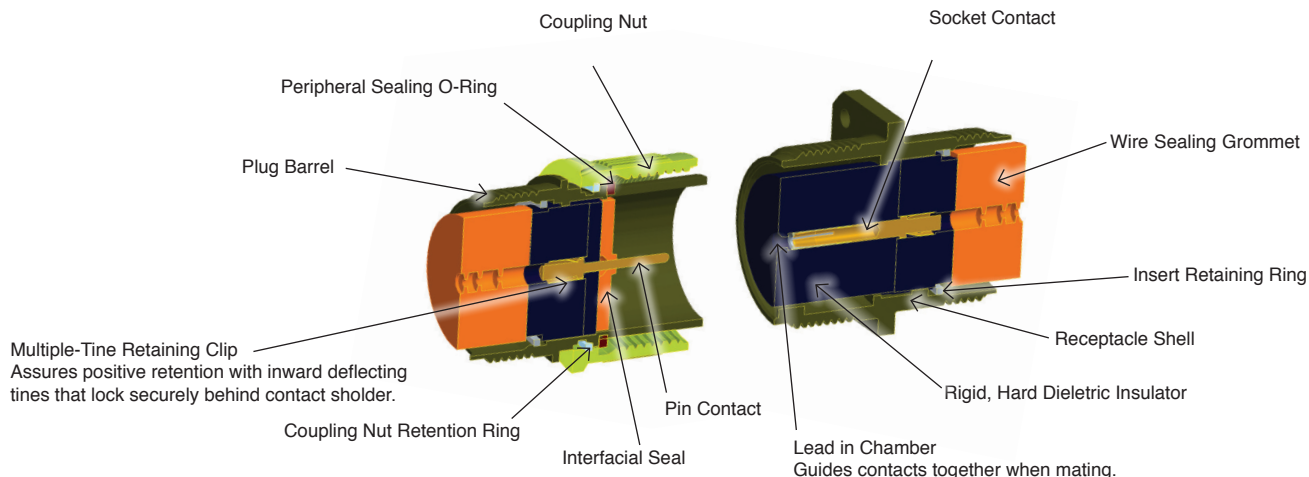

All dimensions in inches (millimeters in parenthesis)

CREATE YOUR PART NUMBER USING THESE SIX STEPS

1	2	3	4	5	6
MS3450	L	18-11	P	W	-LC

SHELL STYLE **FINISH** **LAYOUT** **CONTACT** **POLARIZATION** **MODIFIER**
(military part number example)
(OMIT FOR NORMAL)

1	2	3	4	5	6
9440	F	18-11	P	W	-190

SHELL STYLE **FINISH** **LAYOUT** **CONTACT** **POLARIZATION** **MODIFIER**
(commercial part number example)
(OMIT FOR NORMAL)

STEP 1: SELECT SHELL STYLE, PLUG OR RECEPTACLE

RECEPTACLES ← Mates with → **PLUGS**

			
 Wall Mount Receptacle + MS3450 (9440)	 Cable Mount Receptacle MS3451 (9441)	 Standard Plug + MS3456 (9446)	 Plug with Self-locking Coupling Nut + MS3459 (9816)
			
 Box Mount Receptacle MS3452 (9442)	 Jam Nut Receptacle + MS3454 (9444)		

+ Most popular

STEP 2: SELECT FINISH

- MILITARY**
- L** = Electroless Nickel
 - W** = Olive Drab Chromate over Cadmium
 - LS** = Stainless Steel Shell, Passivated
 - KT**** = Steel Shell, Olive Drab Chromate over Cadmium, Firewall
 - KS**** = Stainless Steel Shell, Passivated, Firewall

- COMMERCIAL**
- A** = Black Anodize
 - F** = Electroless Nickel
 - W** = Olive Drab Chromate over Cadmium
 - FS** = Stainless Steel Shell, Passivated
 - KT** = Steel Shell, Olive Drab Chromate over Cadmium, Firewall
 - KS** = Stainless Steel Shell, Passivated, Firewall

** KT and KS finishes are not QPLD for styles MS3451, MS3452 and MS3454.

STEP 3: SELECT LAYOUT (LISTED BY SHELL SIZE)

For listing by # of contacts, ⇨ see page 72-82.

8S-1	16-12	20-14	22-27*	28-11	36-7
10S-2	16-13	20-15	22-30*	28-12	36-8
10SL-3	18-1	20-16	22-32*	28-13*	36-9
10SL-4	18-4	20-17	22-36*	28-15	36-10
12S-1*	18-5 S	20-18	24-2	28-16*	36-11*
12S-2*	18-6 S	20-19	24-4*	28-17	36-12*
12S-3	18-7*	20-21	24-5	28-18*	36-15
12S-4	18-8	20-22	24-6*	28-19*	36-16*
12-5	18-9	20-24	24-7	28-20	36-17*
14S-1	18-10	20-27	24-10	28-21	36-18*
14S-2	18-11	20-29	24-11	28-22	36-21*
14S-5	18-12	20-32*	24-12	32-1	36-52
14S-6	18-13	20-33	24-15*	32-2*	36-66*
14S-7	18-14*	22-2	24-16*	32-3*	40-1
14S-9	18-15 Δ	22-4 S	24-20	32-6	40-2*
14S-10*	18-16*	22-5	24-21*	32-7	40-3*
14S-11*	18-17*	22-6	24-22	32-9	40-4*
14S-12*	18-18*	22-7 P	24-24*	32-13	40-6*
14S-13*	18-19*	22-9*	24-27*	32-15	40-7*
14-3	18-22	22-10*	24-28	32-16*	40-9
16S-1	18-23*	22-11*	24-80*	32-17	40-56
16S-3*	18-24*	22-14	28-1	32-19*	40-62*
16S-4*	18-27* S	22-15*	28-2	32-20*	
16S-8	18-28* S	22-17*	28-3*	32-22*	
16-2*	20-2	22-18*	28-4*	32-63	
16-7*	20-4	22-19	28-5*	32-73	
16-9	20-7	22-21	28-8*	36-3	
16-10	20-8	22-22	28-9	36-5	
16-11	20-9*	22-23	28-10	36-6	

*non-QPL, commercial only S = Tooled for sockets only P = Tooled for pins only Δ = QPL for pins only, sockets commercial only

STEP 4: SELECT CONTACT

P = Pin
S = Socket
A = Less Pin Contacts (*military only*)
B = Less Socket Contact (*military only*)
 The "A" and "B" designators are used only for non-power contacts (*PCB, coax, thermocouple, or fibre optic contacts*)

STEP 5: SELECT POLARIZATION

(Omit for normal)
W, X, Y, Z
 See ⇨ pages 83-93 for valid polarization.

STEP 6: SELECT MODIFIER

MILITARY & COMMERCIAL
LC = Less Contacts (*not marked on parts*)

COMMERCIAL ONLY
189 = E-nut M85049/31
190 = Straight strain relief
191 = 90 degree strain relief



TIP: Make it easy! Order your connector, backshell and accessories with just one part number using our Cable Assembly Cookbook. See www.peigenesis.com/en/solution-guides.html

DIMENSIONS

RECEPTACLES

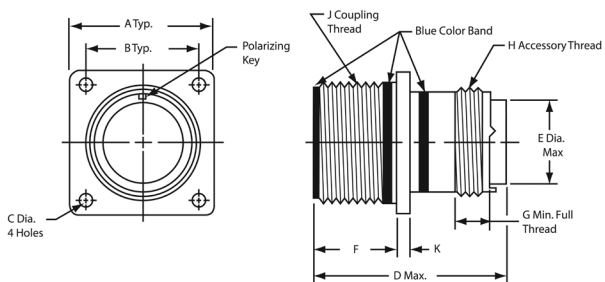

MS3450 (9440)

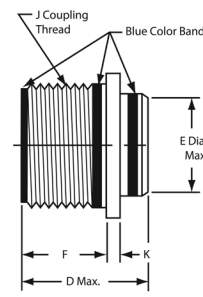

MS3452 (9442)

SHELL SIZE	MS3450, MS3451, MS3452, MS3454	MS3450	MS3450, MS3452				MS3452			MS3450, MS3451, MS3452	
	J THREAD CLASS 2A	F MAX./MIN.	A +/- .031	B	C +.010 / -.005		F MAX./MIN.	D MAX.		E DIA. +/- .016	K
					CLASSES A, F, L, W	CLASSES KT, KS		SIZE 16&12 CONTACTS	SIZE 8,4,0 CONTACTS		
8S	.5000-28 UNEF	.593/.562	0.875	0.594	0.120 (3.0)	0.150 (3.8)	.578/.562	1.662	-	0.500	0.083
10S	.6250-24 UNEF	.593/.562	1.000	0.719	0.120 (3.0)	0.150 (3.8)	.578/.562	1.662	-	0.625	0.083
10SL	.6250-24 UNEF	.593/.562	1.000	0.719	0.120 (3.0)	0.150 (3.8)	.578/.562	1.662	-	0.625	0.083
12	.7500-20 UNEF	.781/.750	1.094	0.812	0.120 (3.0)	0.150 (3.8)	.765/.750	1.662	-	0.750	0.083
12S	.7500-20 UNEF	.593/.562	1.094	0.812	0.120 (3.0)	0.150 (3.8)	.578/.562	1.662	-	0.750	0.083
14	.8750-20 UNEF	.781/.750	1.188	0.906	0.120 (3.0)	0.150 (3.8)	.765/.750	1.662	-	0.875	0.083
14S	.8750-20 UNEF	.593/.562	1.188	0.906	0.120 (3.0)	0.150 (3.8)	.578/.562	1.662	-	0.875	0.083
16	1.0000-20 UNEF	.781/.750	1.281	0.969	0.120 (3.0)	0.150 (3.8)	.765/.750	1.662	1.937	1.000	0.083
16S	1.0000-20 UNEF	.593/.562	1.281	0.969	0.120 (3.0)	0.150 (3.8)	.578/.562	1.662	-	1.000	0.083
18	1.1250-18 UNEF	.781/.750	1.375	1.062	0.120 (3.0)	0.177 (4.5)	.765/.750	1.662	1.937	1.062	0.125
20	1.2500-18 UNEF	.781/.750	1.500	1.156	0.120 (3.0)	0.177 (4.5)	.765/.750	1.662	1.937	1.187	0.125
22	1.3750-18 UNEF	.781/.750	1.625	1.250	0.120 (3.0)	0.177 (4.5)	.765/.750	1.662	1.937	1.312	0.125
24	1.5000-18 UNEF	.843/.812	1.750	1.375	0.147 (3.7)	0.177 (4.5)	.827/.812	1.662	1.937	1.437	0.125
28	1.7500-18 UNS	.843/.812	2.000	1.562	0.147 (3.7)	0.177 (4.5)	.827/.812	1.662	1.937	1.750	0.125
32	2.0000-18 UNS	.906/.875	2.250	1.750	0.173 (4.4)	0.209 (5.3)	.988/.875	1.662	1.937	2.000	0.125
36	2.2500-16 UN	.906/.875	2.500	1.938	0.173 (4.4)	0.209 (5.3)	.988/.875	1.662	1.937	2.250	0.125
40	2.5000-16 UN	.906/.875	2.750	2.188	0.173 (4.4)	0.209 (5.3)	.988/.875	1.662	1.937	2.500	0.125

PLUG SHELL SIZES 8S-16S

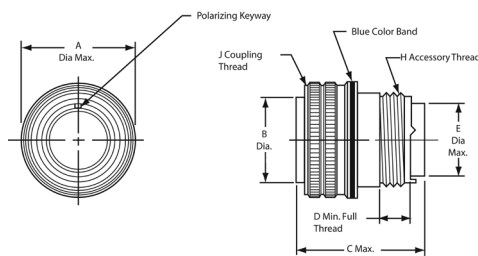

MS3456 (9446)

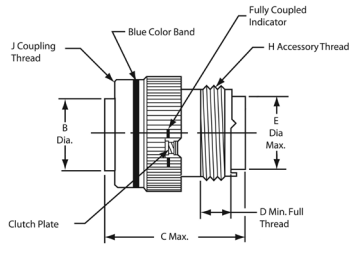

MS3459 (9816)

SHELL SIZE	MS3456, MS3459					MS3456			MS3459		
	B DIA. +/- .005	D MIN.	E DIA. MAX.	H THREAD CLASS 2A	J THREAD CLASS 2A	C MAX.		A DIA. MAX.	C MAX.		A DIA. MAX.
						SIZE 16&12 CONTACTS	SIZE 8,4,0 CONTACTS		SIZE 16&12 CONTACTS	SIZE 8,4,0 CONTACTS	
8S	0.360	0.290	0.305	.5000-20 UNEF	.5000-20 UNEF	2.031	-	0.844	1.510	-	0.963
10S	0.435	0.290	0.405	.6250-24 UNEF	.6250-24 UNEF	2.031	-	0.969	1.510	-	1.088
10SL	0.441**	0.290	0.405	.6250-24 UNEF	.6250-24 UNEF	2.031	-	0.969	1.510	-	1.088
12	0.550	0.290	0.549	.7500-20 UNEF	.7500-20 UNEF	2.125	-	1.062	1.780	-	1.213
12S	0.550	0.290	0.549	.7500-20 UNEF	.7500-20 UNEF	2.031	-	1.062	1.510	-	1.213
14	0.670	0.290	0.665	.8750-20 UNEF	.8750-20 UNEF	2.125	-	1.156	1.780	-	1.358
14S	0.670	0.290	0.665	.8750-20 UNEF	.8750-20 UNEF	2.031	-	1.156	1.510	-	1.358
16	0.800	0.290	0.790	1.0000-20 UNEF	1.0000-20 UNEF	2.125	2.500	1.250	1.780	2.500	1.463
16S	0.800	0.290	0.790	1.0000-20 UNEF	1.0000-20 UNEF	2.031	-	1.250	1.510	-	1.463

All dimensions in inches ** Tolerance on this dimension is +.000/-.006

RECEPTACLES

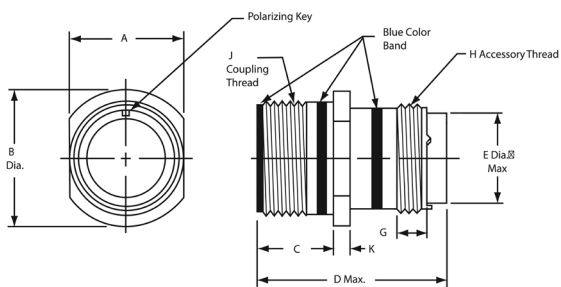

MS3451 (9441)

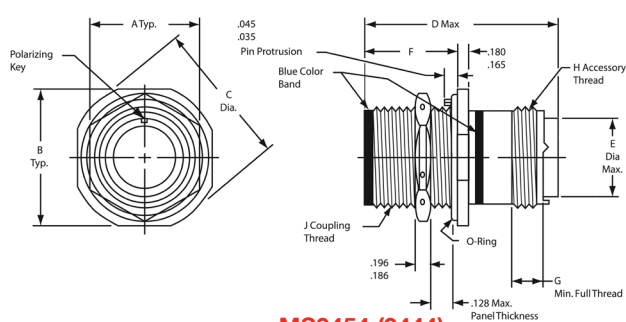

MS3454 (9444)

SHELL SIZE	MS3450, MS3451, MS3454					MS3451			MS3454			
	D MAX.		H THREAD CLASS 2A	E DIA. MAX.	G MIN.	A MAX./MIN.	B DIA. +/- .031	C MAX./MIN.	A +/- .010	B +/- .005	C DIA. +/- .005	F +/- .005
SIZE 16&12 CONTACTS	SIZE 8,4,0 CONTACTS											
8S	2.031	-	.5000-20 UNEF	0.305	0.290	.504/.496	0.729	.577/.562	0.687	1.187	1.272	0.720
10S	2.031	-	.6250-24 UNEF	0.405	0.290	.629/.621	0.854	.577/.562	0.812	1.312	1.397	0.720
10SL	2.031	-	.6250-24 UNEF	0.405	0.290	.629/.621	0.854	.577/.562	0.812	1.312	1.397	0.720
12	2.125	-	.7500-20 UNEF	0.549	0.290	.754/.746	0.974	.765/.750	0.937	1.437	1.522	0.970
12S	2.031	-	.7500-20 UNEF	0.549	0.290	.754/.746	0.974	.577/.562	0.937	1.437	1.522	0.720
14	2.125	-	.8750-20 UNEF	0.665	0.290	.879/.871	1.099	.765/.750	1.125	1.562	1.647	0.970
14S	2.031	-	.8750-20 UNEF	0.665	0.290	.879/.871	1.099	.577/.562	1.125	1.562	1.647	0.720
16	2.125	2.500	1.0000-20 UNEF	0.790	0.290	1.005/.996	1.224	.765/.750	1.250	1.687	1.772	0.970
16S	2.031	-	1.0000-20 UNEF	0.790	0.290	1.005/.996	1.224	.577/.562	1.250	1.687	1.772	0.720
18	2.125	2.500	1.0625-18 UNEF	0.869	0.290	1.131/1.121	1.349	.765/.750	1.375	1.812	1.897	0.970
20	2.125	2.500	1.1875-18 UNEF	0.994	0.290	1.256/1.246	1.474	.765/.750	1.500	1.937	2.022	0.970
22	2.125	2.500	1.3125-18 UNEF	1.119	0.290	1.381/1.371	1.599	.765/.750	1.625	2.156	2.241	0.970
24	2.125	2.500	1.4375-18 UNEF	1.244	0.290	1.506/1.496	1.715	.827/.812	1.750	2.281	2.366	0.970
28	2.125	2.500	1.7500-18 UNS	1.465	0.467	1.756/1.746	1.974	.827/.812	2.000	2.531	2.616	0.970
32	2.125	2.500	2.0000-18 UNS	1.715	0.467	2.007/1.996	2.224	.890/.870	2.375	2.781	2.866	0.970
36	2.125	2.500	2.2500-16 UN	1.930	0.467	2.257/2.246	2.474	.890/.870	2.625	3.031	3.116	0.970
40	2.125	2.500	2.5000-16 UN	2.145	0.467	2.511/2.456	2.724	.890/.870	2.875	3.281	3.366	0.970

PLUG SHELL SIZES 18-40

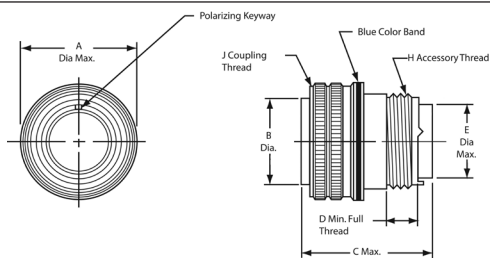

MS3456 (9446)

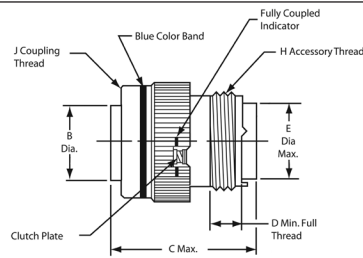

MS3459 (9816)

SHELL SIZE	MS3456, MS3459					MS3456			MS3459		
	B DIA. +/- .005	D MIN.	E DIA. MAX.	H THREAD CLASS 2A	J THREAD CLASS 2A	C MAX.		A DIA. MAX.	C MAX.		A DIA. MAX.
						SIZE 16&12 CONTACTS	SIZE 8,4,0 CONTACTS		SIZE 16&12 CONTACTS	SIZE 8,4,0 CONTACTS	
18	0.925	0.290	0.869	1.0625-18 UNEF	1.1250-18 UNEF	2.125	2.500	1.344	1.850	2.500	1.588
20	1.045	0.290	0.994	1.1875-18 UNEF	1.2500-18 UNEF	2.125	2.500	1.469	1.850	2.500	1.713
22	1.170	0.290	1.119	1.3125-18 UNEF	1.3750-18 UNEF	2.125	2.500	1.594	1.850	2.500	1.788
24	1.295	0.467	1.244	1.4375-18 UNEF	1.5000-18 UNEF	2.125	2.500	1.719	1.850	2.500	1.963
28	1.515	0.467	1.465	1.7500-18 UNS	1.7500-18 UNS	2.125	2.500	1.969	1.850	2.500	2.213
32	1.765	0.467	1.715	2.0000-18 UNS	2.0000-18 UNS	2.125	2.500	2.219	1.850	2.500	2.463
36	1.975	0.467	1.930	2.2500-16 UN	2.2500-16 UN	2.125	2.500	2.469	1.850	2.500	2.713
40	2.225	0.467	2.145	2.5000-16 UN	2.5000-16 UN	2.125	2.500	2.719	1.850	2.500	2.963

All dimensions in inches (millimeters in parenthesis)

CONTACTS

PINS

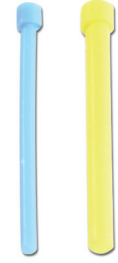
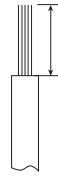

Head goes in first, trim excess

CONTACT SIZE	WIRE SIZE AWG	PIN CONTACT PART NUMBER	COLOR BANDS			WIRE STRIP LENGTHS	WIRE INSULATION RANGE		WIRE HOLE FILLER	COLOR
			1	2	3		MIN.	MAX.		
16S	16, 18 & 20	M39029/29-212	Red	Brown	Red	.245 (6.2)	.053 (1.35)	.103 (2.62)	MS27488-16-3	Blue
16	16, 18 & 20	M39029/29-212	Red	Brown	Red	.245 (6.2)	.053 (1.35)	.103 (2.62)	MS27488-16-3	Blue
12	12 & 14	M39029/29-213	Red	Brown	Orange	.245 (6.2)	.085 (2.16)	.158 (4.01)	MS27488-12-3	Yellow
8	8 & 10	M39029/29-214	Red	Brown	Yellow	.465 (11.8)	.132 (3.35)	.255 (6.48)	MS27488-8-3	Red
4	4 & 6	M39029/29-215	Red	Brown	Green	.465 (11.8)	.237 (6.02)	.370 (9.40)	MS27488-4-3	Blue
0	0 & 2	M39029/29-216	Red	Brown	Blue	.540 (13.7)	.360 (9.14)	.550 (13.97)	MS27488-0-3	Yellow

Thermocouples available, please contact us using the contact information below.

SOCKETS

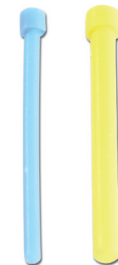

Head goes in first, trim excess

CONTACT SIZE	WIRE SIZE AWG	PIN CONTACT PART NUMBER	COLOR BANDS			WIRE STRIP LENGTHS	WIRE INSULATION RANGE		WIRE HOLE FILLER	COLOR
			1	2	3		MIN.	MAX.		
16S	16, 18 & 20	M39029/30-217	Red	Brown	Violet	.245 (6.2)	.053 (1.35)	.103 (2.62)	MS27488-16-3	Blue
16	16, 18 & 20	M39029/30-218	Red	Brown	Gray	.245 (6.2)	.053 (1.35)	.103 (2.62)	MS27488-16-3	Blue
12	12 & 14	M39029/30-219	Red	Brown	White	.245 (6.2)	.085 (2.16)	.158 (4.01)	MS27488-12-3	Yellow
8	8 & 10	M39029/30-220	Red	Red	Black	.465 (11.8)	.132 (3.35)	.255 (6.48)	MS27488-8-3	Red
4	4 & 6	M39029/30-221	Red	Red	Brown	.465 (11.8)	.237 (6.02)	.370 (9.40)	MS27488-4-3	Blue
0	0 & 2	M39029/30-222	Red	Red	Red	.540 (13.7)	.360 (9.14)	.550(13.97)	MS27488-0-3	Yellow

All dimensions in inches (millimeters in parenthesis)

Thermocouples available, please contact us using the contact information below.

PINS

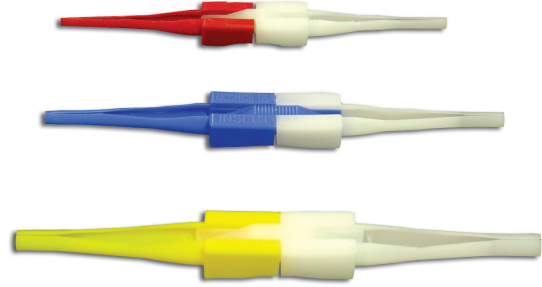
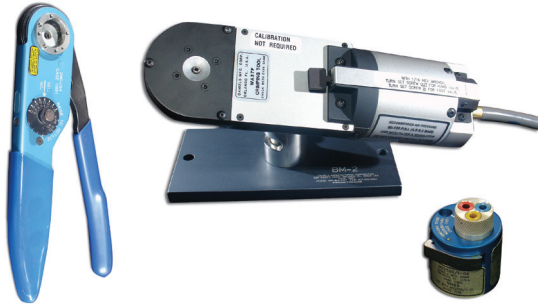

CONTACT SIZE	HAND-CRIMP TOOL	POWER-CRIMP TOOL	TURRET HEADS	USE LOCATOR COLOR	METAL		PLASTIC		
					INSERTION TOOL	EXTRACTION TOOL	INSERTION/EXTRACTION TOOL	INSERTION TIP COLOR	EXTRACTION TIP COLOR
16S	M22520/1-01	WA27F	M22520/1-02	Blue	DAK83-16B	DRK83-16B	M81969/14-03	Blue	White
16	M22520/1-01	WA27F	M22520/1-02	Blue	DAK83-16B	DRK83-16B	M81969/14-03	Blue	White
12	M22520/1-01	WA27F	M22520/1-02	Yellow	DAK83-12B	DRK83-12B	M81969/14-04	Yellow	White
8	-	M22520/23-01	M22520/23-02 die w/ M22520/23-09 locator	-	-	-	M81969/29-02	-	Red
4	-	M22520/23-01	M22520/23-04 die w/ M22520/23-11 locator	-	-	-	M81969/29-03	-	Blue
0	-	M22520/23-01	M22520/23-05 die w/ M22520/23-13 locator	-	-	-	M81969/29-04	-	Yellow

SOCKETS

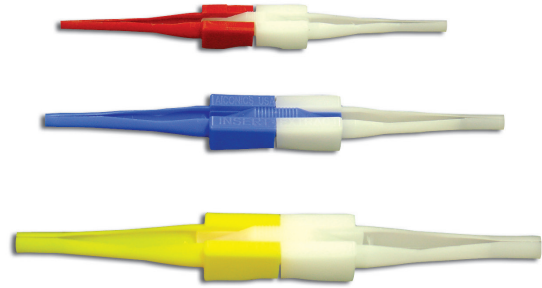
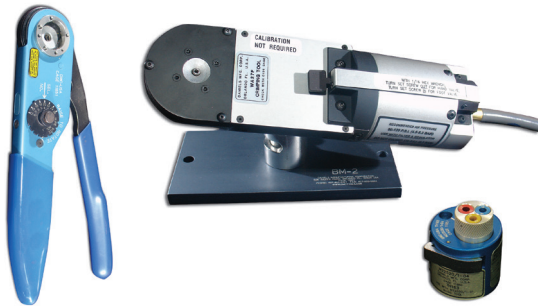

CONTACT SIZE	HAND-CRIMP TOOL	POWER-CRIMP TOOL	TURRET HEADS	USE LOCATOR COLOR	METAL		PLASTIC		
					INSERTION TOOL	EXTRACTION TOOL	INSERTION/EXTRACTION TOOL	INSERTION TIP COLOR	EXTRACTION TIP COLOR
16S	M22520/1-01	WA27F	M22520/1-02	Blue	DAK83-16B	DRK83-16B	M81969/14-03	Blue	White
16	M22520/1-01	WA27F	M22520/1-02	Blue	DAK83-16B	DRK83-16B	M81969/14-03	Blue	White
12	M22520/1-01	WA27F	M22520/1-02	Yellow	DAK83-12B	DRK83-12B	M81969/14-04	Yellow	White
8	-	M22520/23-01	M22520/23-02 die w/ M22520/23-09 locator	-	-	-	M81969/29-02	-	Red
4	-	M22520/23-01	M22520/23-04 die w/ M22520/23-11 locator	-	-	-	M81969/29-03	-	Blue
0	-	M22520/23-01	M22520/23-05 die w/ M22520/23-13 locator	-	-	-	M81969/29-04	-	Yellow

All dimensions in inches (millimeters in parenthesis)

PANEL CUTOUTS

MS3450 (9440)

MS3452 (9442)

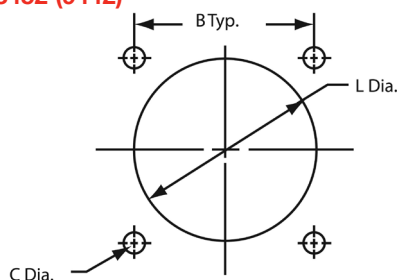

MS3454 (9444)

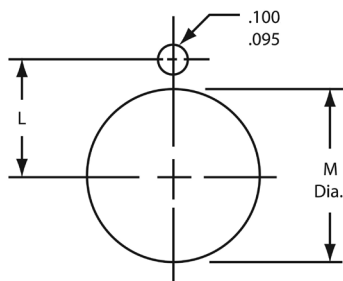

SHELL SIZE	MS3450/MS3452			MS3450	MS3454	
	B	L DIA. +/- .010	C DIA. +.010/- .005	CLASS K C DIA. +.010/- .005	L +/- .005	M DIA. +.015/- .000
8S	0.594	0.562	0.120	0.150	0.323	0.505
10S	0.719	0.688	0.120	0.150	0.385	0.630
10SL	0.719	0.688	0.120	0.150	0.385	0.630
12	0.812	0.812	0.120	0.150	0.448	0.755
12S	0.812	0.812	0.120	0.150	0.448	0.755
14	0.906	0.938	0.120	0.150	0.510	0.880
14S	0.906	0.938	0.120	0.150	0.510	0.880
16	0.969	1.062	0.120	0.150	0.573	1.005
16S	0.969	1.062	0.120	0.150	0.573	1.005
18	1.062	1.188	0.120	0.177	0.635	1.130
20	1.156	1.312	0.120	0.177	0.698	1.255
22	1.250	1.438	0.120	0.177	0.760	1.380
24	1.375	1.562	0.147	0.177	0.823	1.505
28	1.562	1.812	0.147	0.177	0.948	1.755
32	1.750	2.062	0.173	0.209	1.073	2.005
36	1.938	2.312	0.173	0.209	1.198	2.255
40	2.188	2.562	0.173	0.209	1.323	2.505

⇒ See page 114 for gaskets.

⇒ See page 490 for nut plates and seal screws.

DUMMY RECEPTACLES & METAL DUST CAPS

DUMMY RECEPTACLES

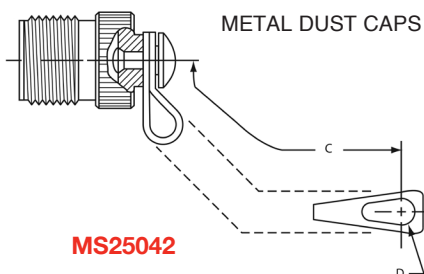
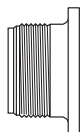
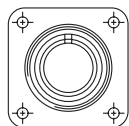

MS25042

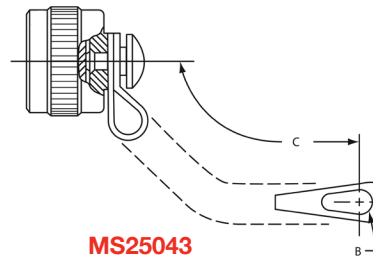

MS25043

SHELL SIZE	DUMMY RECEPTACLES	METAL DUST CAPS		C APPROX.	D DIA. +.010/- .005	B DIA. +.010/- .005
		PLUG	RECEPTACLE			
8S	MS3105-8	MS25042-8DA	MS25043-8DA	4.000	0.156	0.140
10S, 10SL	MS3105-10	MS25042-10DA	MS25043-10DA	4.000	0.156	0.140
12, 12S	MS3105-12	MS25042-12DA	MS25043-12DA	4.500	0.156	0.140
14, 14S	MS3105-14	MS25042-14DA	MS25043-14DA	4.500	0.156	0.140
16S	MS3105-16	MS25042-16DA	MS25043-16DA	4.500	0.156	0.140
16	MS3105-17	MS25042-16DA	MS25043-16DA	4.500	0.156	0.140
18	MS3105-18	MS25042-18DA	MS25043-18DA	4.500	0.156	0.140
20	MS3105-20	MS25042-20DA	MS25043-20DA	5.000	0.187	0.140
22	MS3105-22	MS25042-22DA	MS25043-22DA	5.000	0.187	0.140
24	MS3105-24	MS25042-24DA	MS25043-24DA	5.500	0.187	0.171
28	MS3105-28	MS25042-28DA	MS25043-28DA	7.750	0.187	0.171
32	MS3105-32	MS25042-32DA	MS25043-32DA	7.750	0.218	0.187
36	MS3105-36	MS25042-36DA	MS25043-36DA	7.750	0.218	0.187
40	MS3105-40	MS25042-40DA	MS25043-40DA	7.750	0.218	0.187

Note: Stainless steel dust caps and other lanyards available, please contact us.

Aluminum alloy with anodized plating is shown. Contact us for other available dust cap materials and platings.

All dimensions in inches (millimeters in parenthesis)

STANDARD CABLE CLAMPS



Light-weight, open-rear design

SHELL SIZE	STRAIGHT CLAMP		90°		CABLE ENTRY	
	LOW-COST	SELF-LOCKING	LOW-COST	SELF-LOCKING	MAX.	MIN.
8	M85049/52-1-8*	M85049/52S8*	M85049/51-1-8*	M85049/51S8*	.204 (5.18)	.125 (3.18)
10S, 10SL	M85049/52-1-10*	M85049/52S10*	M85049/51-1-10*	M85049/51S10*	.286 (7.26)	.187 (4.75)
12, 12S	M85049/52-1-12*	M85049/52S12*	M85049/51-1-12*	M85049/51S12*	.416 (10.57)	.291 (7.39)
14, 14S	M85049/52-1-14*	M85049/52S14*	M85049/51-1-14*	M85049/51S14*	.476 (12.09)	.351 (8.92)
16, 16S	M85049/52-1-16*	M85049/52S16*	M85049/51-1-16*	M85049/51S16*	.626 (15.88)	.501 (12.72)
18	M85049/52-1-18*	M85049/52S18*	M85049/51-1-18*	M85049/51S18*	.706 (17.93)	.518 (13.16)
20	M85049/52-1-20*	M85049/52S20*	M85049/51-1-20*	M85049/51S20*	.831 (21.11)	.581 (14.76)
22	M85049/52-1-22*	M85049/52S22*	M85049/51-1-22*	M85049/51S22*	.956 (24.28)	.644 (16.36)
24	M85049/52-1-24*	M85049/52S24*	M85049/51-1-24*	M85049/51S24*	1.081 (27.46)	.706 (17.93)
28	M85049/52-1-28*	M85049/52S28*	M85049/51-1-28*	M85049/51S28*	1.187 (30.15)	.750 (19.05)
32	M85049/52-1-32*	M85049/52S32*	M85049/51-1-32*	M85049/51S32*	1.250 (31.75)	.875 (22.23)
36	M85049/52-1-36*	M85049/52S36*	M85049/51-1-36*	M85049/51S36*	1.375 (34.93)	.938 (23.83)
40	M85049/52-1-40*	M85049/52S40*	M85049/51-1-40*	M85049/51S40*	1.500 (38.10)	.938 (23.83)

* Select plating code to match connector plating.

N = Electroless Nickel-Plated Aluminum Alloy

W = Olive Drab Chromate over Cadmium over Electroless Nickel-Plated Aluminum Alloy

S = Stainless Steel

	DESCRIPTION	PART NUMBER PREFIX	STRAIGHT	90°	45°
	Heat Shrink Boot Adapter → See pages 491-492	M85049/60	X		
	Environmental	M85049/7			X
		M85049/9		X	
		M85049/11	X		
	EMI/RFI Non-Environmental	M85049/23			X
		M85049/24		X	
		M85049/25	X		
	EMI/RFI Environmental	M85049/6			X
		M85049/8		X	
		M85049/10	X		
	EMI/RFI Crimp Ring	M85049/26	X		
	EMI/RFI Banding	M85049/82	X		
		M85049/83			X
		M85049/84		X	
	Cable Tie	M85049/55		X	
		M85049/53	X		
		M85049/54			X
	Wire Seal	M85049/31	X		
	Compression Nuts "E"				

Note: If military standard versions won't fit your applications, please contact us with your requirements.

All dimensions in inches (millimeters in parenthesis)

WIRE-STRIPPING AND CONTACT-CRIMPING

.245 (6.2) for #16/16S Contact .465 (11.8) for #8 Contact .540 (13.7) for #0 Contact

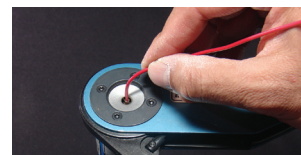
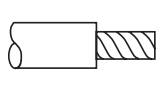
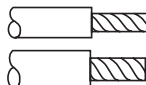
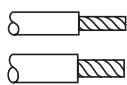

.245 (6.2) for #12 Contact .465 (11.8) for #4 Contact

STEP 1: Strip wires. (See above for correct strip length by contact.) Insert wire into rear of contact. Wire insulation must push against rear of contact. Wire must be visible through inspection hole.

STEP 2: Use M22520/1-01 crimp tool with proper crimp locator M22520/1-02. → See pages 56-57 for additional tooling.

CONTACT SIZE	COLOR
16/16S	Blue
12	Yellow

STEP 3: Insert contact and wire into tool jaws. To crimp, squeeze handles together fully until ratchet releases and allows handles to expand, otherwise contact cannot be extracted from tool jaws. Maintain slight insertion pressure on wire while crimping contact to wire.*

CONTACT INSERTION

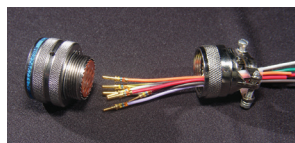

STEP 1: Remove backshell and put wired contacts through cable clamp opening.

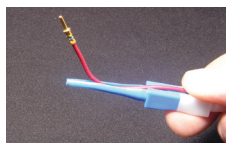

STEP 2: Use colored end of CIET tool for insertion. Place wire into tool at large opening. To facilitate contact insertion, a six-inch minimum of free wire is recommended.

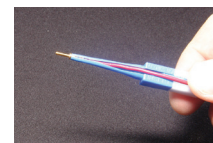

STEP 3: Slide back tool on wire while holding thumb against wire at opening. Wire will slip into tool.



STEP 4: With tool pressed against shoulder of contact, starting at the center cavity, insert wired contact and tool into properly-identified cavity at rear of plug with firm, even pressure. Do not use excessive pressure.

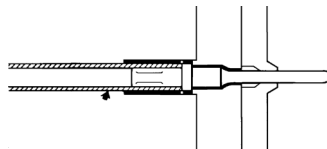

STEP 5: When contact touches bottom, a slight click can be heard as tines of metal retaining clip snap into place behind contact shoulder.

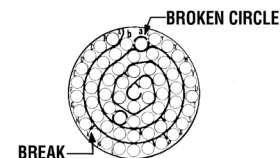

STEP 6: Check face of plug or receptacle for proper contact installation. In socket inserts with a large number of contacts, cavities are identified in a spiral pattern. A projecting line from the spiral indicates omission of a letter; a broken circle around a cavity indicates transition between capitals, and lower case and double letters.



STEP 7: Withdraw tool from rear of plug. To be sure that contact is locked, pull back lightly on wire. Remove tool from wire and proceed with other contacts.

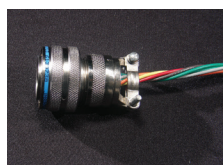

STEP 8: After all contacts are inserted, fill unwired cavities with sealing plugs (insert head first and leave end protruding for ease of removal), assemble backshell on rear of connector.



SEE PAGE 122 for endbell tightening tools.

* **IMPORTANT NOTE:** Microsection the contact to verify crimp quality.

CONTACT EXTRACTION

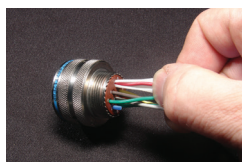

STEP 1: Remove backshell and slide back along wires to allow access. To extract a contact, use white end of CIET tool. Place wire into tool at large opening. Slide back tool on wire while holding thumb against wire at opening. Wire will slip into tool.

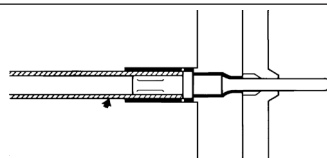

STEP 2: Push tool into rear of plug until it touches bottom. At this point, tool releases; tines on retaining clip so that contact can be extracted.

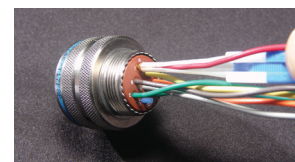

STEP 3: While maintaining slight insertion force on tool, firmly hold wire against serrated shoulder at center of tool and extract both wired contact and tool from plug.

Note: LJT Series shown.